

INSTALLATION INSTRUCTIONS: PART #5355
T-REX Radius Arms, 1966-79 Bronco, 67-79 F-150 4WD



865.938.6696 www.dufftuff.com
 6609 Bronco Lane
 Knoxville, TN 37921

CONTENTS:

1	Drivers side Radius Arm	2	1/2" x 4" NC GR 5 Bolts
1	Passenger Side Radius Arm	2	1/2" Nyloc Nuts
2	Radius Arm Cast Head Units	4	1/2" Flat washers
4	5/8" x 4" GR 8 Bolts	2	7/16" x 1.25" NC GR 5 Bolts
4	5/8" Nyloc Nuts	2	7/16" Split Lock washer
8	5/8" Flat washers	2	9/16" x 3.5" GR 5 Bolts
4	Head Unit Bushing Sleeves	8	9/16" x 2 1/4" NC GR 8 Bolts
8	Head Unit Bushings (#M03133)	4	7/8" USS Washers
2	3/4" NC Flanged Nut	8	9/16" Lock Washers

1/4 3/17



Shown with optional #6100

NOTES: Lay out and verify all parts you may need are accounted for before you tear down your Bronco. This is especially important if you have a rented space or if a mechanic/shop is doing the install. We recommend that you have a caster reading taken at a front end alignment shop before installation to assure you have the proper degree bushing, so you won't be held up waiting for them or have to tear it back down and reinstall. We recommend a reading of 3.5 to 4.5°+. Too much or too little will result in caster shimmy or wandering. Take into consideration when calculating for the proper bushings, there is 4.25°+ built into these arms. Also, give your track bar a quick shake and inspection to check the condition of the bushings. It will be disconnected and they'll be easy to replace.

Please read all instructions before beginning.

1. Disconnect the breather hose from the front axle. With a 9/16" wrench, loosen and remove the breather extension. It secures the brake junction block to the center section, let it dangle freely. Disconnect the front drive line at the front axle yoke, let it dangle as well. Break free the lug nuts on the front wheels, but don't loosen them.
2. Block the rear tires, raise the front of the vehicle and place jack stands under the frame so the front axle will hang by the coil springs. (You may have to remove the front bumper if you don't have room behind it for the frame stands.) Support the axle with a floor jack so that you can manipulate its height during installation. Remove the wheels. **CAUTION: Make sure your frame to axle brake line has sufficient length. Even with it disconnected you should keep an eye on it.**
3. Remove the track bar at the frame and secure it to the axle. Remove the drag link at the pitman arm and secure it to the tie rod.
4. Go to the radius arm frame mount and locate the large nut holding the arm into the mount. Use a pair of needle nose pliers and remove the cotter pin in the arm behind the nut. Use a 1 1/8" socket with an impact gun and remove the nut, the washer and the large rubber bushing. Repeat this step for the other side.
5. Remove the 4 bolts holding the stock arm to the C-cap using a 13/16" socket. Wiggle the arm and axle until the arm is free of the frame mount. Once the arms are disconnected, use a small jack stand or a 4x4 wood block and wedge it under the pinion snout. This will be a very helpful when you get to step 10.
6. This is a good time to clean and repaint the axle and C-caps. You may find scale rust has built up under the c-bushings on the C-caps and axle. Scrape or chisel that away, prep for paint then use black chassis paint to prevent future rust.
7. With parts painted and ready for install, it's time to assemble the arms. Note: Although the bushings are self lubricating, we recommend lube for installation. A lithium based grease is best, but petroleum will work. The lithium grease will outlast petroleum and prevent squeaking, as well as improve articulation. Insert the bushings into the head unit, then press the 2" sleeves into the bushings. NOTE: The tolerance of the holes in the head unit are very tight to prevent bushings wear. Be patient and firm using a light tap of a hammer to start the bushings in the holes.
8. Using generous amounts of lube, coat the inside and outside of the bushings. Be sure to orientate them correctly by reading the inside edge of it. If you mount them upside down, your caster will be drastically off. NOTE: Because these radius arms have 4.25° of caster built into them, you will be able to run a lesser degreed C bushing and achieve the same caster reading. Normally a 2 or 4° C bushing can be used with a 2.5" lift and our arms.
9. Slide the C bushing into the head unit. NOTE: Make sure the 7/16" threaded hole is at the top of head unit. This hole has to face up because that is where your coil spring retainer attaches. Position the other C bushing into the C cap, again make sure it also is facing the correct way, so there is a threaded hole at the top. We have supplied you with 2 9/16" x 3.5" Grade 5 bolts,

these are starter bolts that will pull the head unit and c cap together close enough so that you can use the 9/16" x 2.25" Grade 8 bolts. **BE SURE TO USE ANTI SEIZE ON ALL OF THESE BOLTS AND DO NOT USE AN IMPACT GUN! Start the longer bolts first diagonal from each other. Using a ratchet, thread them in a little at a time. If they don't thread in easily, back them back out and back in until the hole becomes easier to thread. Do not bottom out the long bolt, this will cause the bolt to seize when trying to remove it. HEAD UNITS ARE VERY EXPENSIVE TO REPLACE, SO GO SLOW AND TAKE YOUR TIME TO PREVENT STRIPPING THE THREADS.** Now install the shorter bolts with 9/16" lock washers. Once the first two are in place and have relieved the tension off the starter bolts, remove them and install the last two short bolts with lock washers. Once you have the shorter bolts threaded in 3 or 4 turns, move on to the other side and repeat step 10. **Do not tighten these down yet, doing so can cause Bronco Lean!**

10. Align the arm to the head unit, so the bent portion is to the inboard side of the Bronco and the shock tab is facing up. Align the upper and lower holes in the head unit with the upper and lower holes in the arm. Use the 5/8" x 4" bolt, two 5/8" washers and a 5/8" Nyloc nut to secure these positions. Use the impact to tighten the bolts until they are snug but still have a little bushing squish and the arm can move side to side. You will tighten these in step 16.

11. Now that the arms are installed and securely tightened to the Head units. It's time to finish tightening the C cap bolts. Grab the driver side arm and prevent it from rotating down. While doing this, remove the small jack stand or wood block under the pinion snout and slowly let the arms rotate down to the ground. Be mindful of the jack stands holding the axle up so the axle doesn't slip off of them. Also keep an eye on your axle to frame brake lines so they don't kink or over extend. Once the ends of the arms are resting on the ground, it is time to tighten the C-cap bolts the rest of the way.

12. Grab your 13/16" socket, 6" extension and 1/2" ratchet driver and get comfortable underneath the front end. The goal here is to manually tighten down your C-caps while keeping both arms frame ends touching the ground. **Make sure to go in a criss cross pattern and jump from the driver side to passenger side frequently. They will lift and drop a little as you tighten the bolts but once you are done tightening all 8 bolts, the arms should be flat on the ground. This is how you prevent the dreaded Bronco Lean.** Once you have all 8 bolts tightened down as hard as you can by hand, use your torque wrench and torque them to 90-110 foot pounds.

13. With the arms properly bolted to the axle, attach the arms to the frame brackets. Using a new set of radius arm strut bushings (#6100) first place a 7/8" USS washer on the threaded end of the arm, then slide a bushing with the flat side facing the washer. We recommend using lithium or petroleum jelly on the bushing where it will make contact with the arm and the frame. Repeat this step for the other side.

14. Note: This step may take 2 people in order to not damage the threads at the end of the arms. Grab the arm and raise it up to the frame bracket. You may have to move the axle forward and side to side a bit until you can get the arm to slide through the hole. A helper can guide the other side in at the same time. It may take a few strong pushes of the axle rearward once the arm ends are through the frame bracket. Once most of the end of the arm is sticking through the other side of the bracket, slide the other arm bushing on with the small end facing forward. If enough threads are exposed to start the 3/4" flanged nut, you can use the nut to cinch the arm into the frame bracket more to make room for the 7/8" USS washer. Remove the nut, install the washer, then repeat for the other side. If you can't get the nut started a come along strap works well to get the front axle back far enough so the arm seats into the frame bracket and you can install the washer and nut. See Fig. 2 for a good visual.

15. Using an impact, tighten the 3/4" flanged nuts until you see the bushings start to compress. Use your torque wrench to tighten them the rest of the way. Start at 80 ft. lbs. and up to a max of 120 ft. lbs. This extra torque may be required in order to install the supplied cotter pin. Once the hole is exposed, slip the cotter pin into the hole that is cross drilled through the end of the arm then bend the end of the cotter pin that slips through to 90°.

16. With an impact, tighten the 5/8" bolts that connect the arm to the head unit until you see the socket stop moving (about 120-150 ft. lbs.) Repeat for the other side.

17. Reinstall the front coil spring retainer cups and coil springs. A 7/16" x 1.25" NC GR 5 bolt and split lock washer are provided for securing the rear hole in the coil spring retaining cup. Torque bolts to 30 ft.lbs.

18. The radius arm shock mounts are designed for one shock behind the coil. Use the supplied 1/2" x 13 NC GR 5 hex bolt, 2 1/2" washers and Nyloc nut to secure the shock. Repeat for the other side.



19. Inspect the trac bar bushings, If they look good, reattach the trac bar. NOTE: You may need a come along strap to get the trac bar frame bracket bolt back in. If the bushings are in bad shape, give us a call or order them online at dufftuff.com #6108 for 66-75 and #6109 for 76-77. Once the trac bar is re-installed, jack the axle up until the frame stands can be removed. Lower the axle back down onto the jack stands so all the weight of the front end is on the coil springs. Don't forget to reattach the brake line and breather bolt to the axle then reattach the driveshaft. Don't over torque the drive shaft u-bolt nuts, it will ruin your u-joints and cause premature failure. Leave the drag link disconnected for now.

20. Reinstall the tires. This may be fun for you because if your steering stops were moved out on the knuckles due to your tires making contact with your stock arms, it's time to loosen them up and move them back in! This may take a few tries but can be easily done with the drag link not attached. Move your tires from lock to lock until you're sure you are getting maximum turning radius without touching anything in front or behind the axle with the tire and wheel. Leave yourself at least 3/8" of clearance before making contact with anything and then tighten the jam nut.

21. Reinstall the drag link and the safety cotter pin and drop the axle off the jack. Torque the lug nuts, look over your work and take the vehicle for a drive.

22. We highly recommend having an alignment to verify proper toe in and caster numbers. Make sure to check all fasteners after the first 50 miles after the install.



Fig. 2

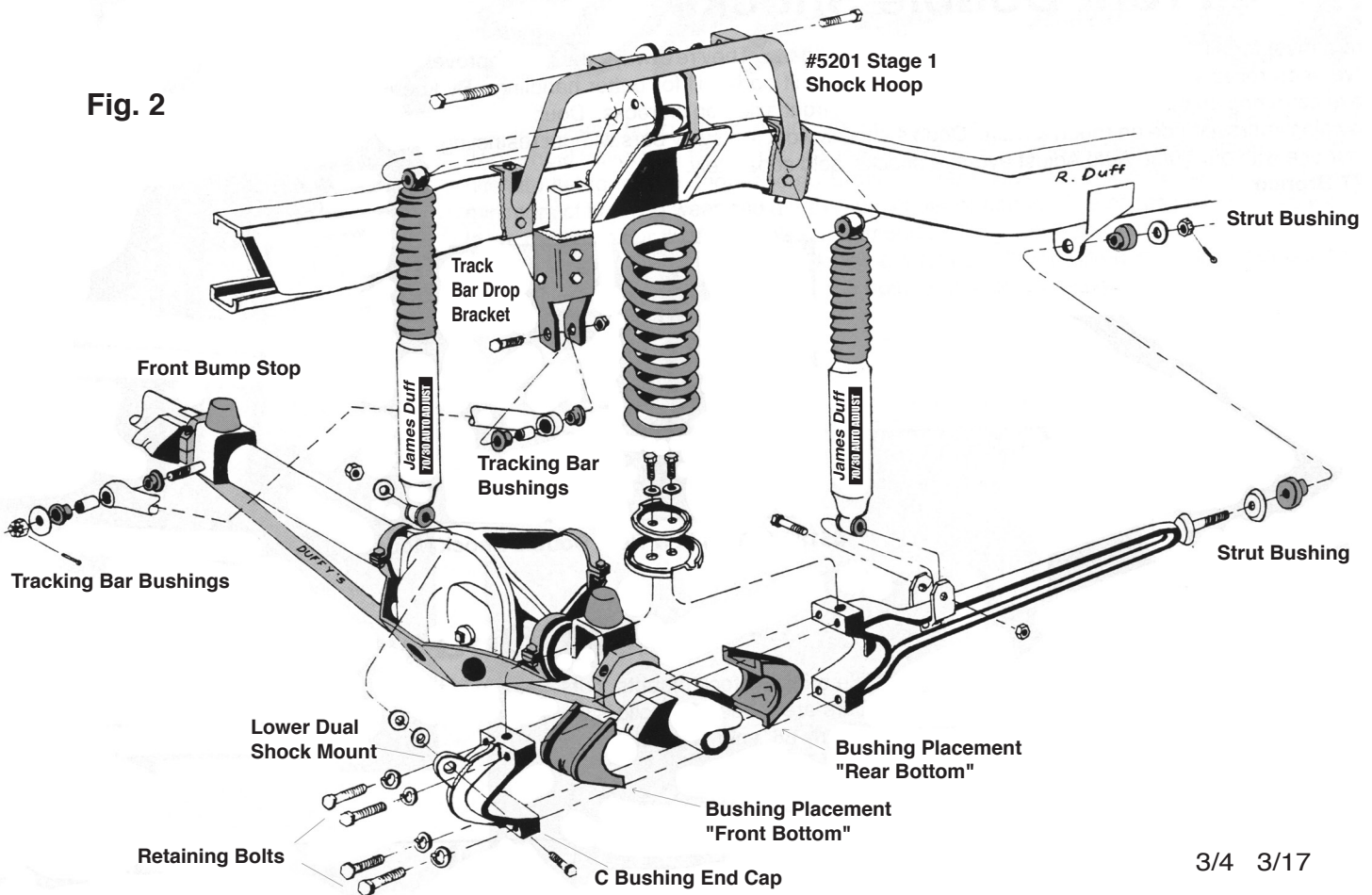

To maximize the performance of your suspension, consider installing our other components:

Adjustable Track Bar

With up to 3" of adjustability this will allow you to fine tune your track bar to get the front end centered under your rig and help correct steering woes. Work with up to 6" of lift with a drop or raise bracket, will align our 2.5" kit alone. Full tig welded 3/16" wall 1.5" DOM with 3/4" threaded rod, machined ends instead of crushed tube found on others. Black powdercoated, includes poly bushings and zinc plated sleeves. #5403-4 66-77 #5408 78-79 Bronco

Tracking Bar Bushings

Worn out tracking bar bushings are the number one cause of front end shimmy. These are two piece polyurethane with zinc plated sleeves. Included in our 14 pc. kits. Note: #6109 is for 76-77 Broncos which have an oval bushing at the frame end. #6108 66-75 EB, 66-79 F100-50, 78-79 Bronco #6109 76-77 Bronco

Stainless Steel Braided Brake Hoses

Our custom lines are stainless steel and DOT approved for street legality as well as being longer to accommodate suspension travel. These lines won't swell under pressure like rubber. Smaller inside diameter increases pedal feel and brake response. We have these specially made so you don't have to guess when it comes to the safety and soundness of your brakes. Fits stock to 6" lifted 66*-77 Broncos. Note: *66 & 67 may need adapted to fit front hose. #3931

CURING THE INFAMOUS BRONCO LEAN

If you have the dreaded "Bronco Lean", chances are you have recently replaced the coils with newer soft coils or you have replaced your "C" bushings. This lean can be measured at the bottom edge of the front fenders, bottom edge of front reflectors or any other handy place, making sure that any body damage or bad body bushings won't affect the numbers. Quite commonly the lean is 2" or more in the front of the Bronco. The cure to this problem follows:

You must disconnect the entire front axle assembly from the Bronco. Disconnect and remove the front coil springs, disconnect the frame to axle brake line, disconnect the front housing breather line, remove the radius arm nuts from the rear mounts. Remove the rear bushings that are on the end of the radius arms. With a set of jack stands supporting the axle (under the front hub assembly on either side works good) lower the threaded end of the radius arms down so they touch the LEVEL concrete floor. It's important that the floor surface is a level, flat surface. With a floor jack under the "pumpkin" or gear housing of the Dana 44 or Dana 30, this makes this step very easy. Look very carefully at the ends of the radius arms. Do they BOTH touch the floor at the SAME time? If one radius arm is touching the floor and the other is not, then this is the most common cause of your Bronco leaning to one side or the other. You must have both radius arms parallel to each other. Are the C bushings installed correctly? Remove them and check the writing on the inside of the poly style bushings to verify correct installation. This step is critical. If the c bushings were installed wrong, then improper installation could be causing the lean.

To correct the lean, you must loosen the 4 bolts that hold the radius arm caps on. Choose one side to start with. By loosening the cap bolts on this side almost all the way out and then tightening them back diagonally or slightly quicker at the top or bottom (try different ways), the c bushing will seat differently. You can vary the distance off the floor of the offending radius arm by 2" or more by proceeding this way. However, sometimes you cannot get the end of the radius arm that you want closer to the floor (more parallel to the other arm), only farther off the floor!! If this is the case, then you must try to get the arm back as close as parallel to the offending arm and then tighten/torque the radius arm bolts. Proceed to loosen the cap bolts on the other arm and repeat the steps you've already tried on the first arm. It may take 5 or 6 times on either or both before you will get the arms parallel to each other. Keep trying. It is hit or miss.

The bushings are IMO, the main culprit for front end lean when new suspensions are installed and the lean is a new condition. Of course this method or example won't solve your problem if your springs are bad or you have other front end problems. However, many Early Bronco owners have emailed me saying that this has cured the "infamous front end lean" in their Broncos.

By Brian Cooke, Courtesy of BroncoFix.com

LIMITED WARRANTY

James Duff Inc. warrants our products to the original purchaser to be free from defects in materials and workmanship. Warranty periods begin at the date of purchase and varies by product. Shocks have a limited lifetime warranty. Headers, Radiators and Suspension Products, Power Brake Boosters and Master Cylinders have a one year warranty. Adapters and soft goods such as upholstery, vinyl and rubber products have a 90 day warranty. All warranties are to the original purchaser with proof of purchase only. Such obligations under this warranty shall be limited to the repair or replacement, at JDI's discretion, of any assembly or part which upon examination by JDI proves to be defective. Any costs of removal, installation, reinstallation or freight charges are expressly excluded from this warranty. This warranty covers only manufacturers defects, and does not cover product finish or damage resulting from abuse, misuse, negligence, racing, alteration, accident or damage in transit.

All returns must be pre-authorized by JDEI and accompanied with a Return Goods Authorization Number (RGA) and a dated proof of purchase. Returns must be made within 90 days of purchase, packaged sufficiently to prevent damage in shipment and sent prepaid to JDI, 6609 Bronco Lane, Knoxville, TN 37921. Returns without an RGA# will be refused.

This warranty is expressly in lieu of all other warranties, expressed or implied, including the implied warranties of merchantability and fitness for use. This warranty gives you specific legal rights including other rights that vary from state to state. Some states do not allow limitations on how long an implied warranty lasts, or do not allow the exclusion of limitation of incidental or consequential damages, so the above limitations and/or exclusions may not apply to you.

SUSPENSION PRODUCT INFORMATION

Modifying your vehicle with JDI products to improve off road performance may result in the vehicle handling differently than a factory equipped vehicle. Taller tires will cause the vehicle's speedometer to read slow, so recalibration is required. Use of oversize tires, suspension lifts, body lifts, and other modifications may raise your vehicle's center of gravity, resulting in an increased tendency for the vehicle to pitch and roll during sudden turns or abrupt maneuvering. Failure to drive with extreme care to prevent loss of control or vehicle roll over may result in injury or death. Drive at a reduced speed to ensure your ability to maintain control of the vehicle under all driving conditions. We recommend installing functional roll bars and cages as well as double shocking all vehicles for more safety and stability on or off road. Always wear seat belts when in a vehicle. Consult your owners manual for recommended tire sizes, safety instruction and warnings unique to your vehicle. It is your responsibility to check state and local laws restricting vehicle height to ensure that modifications to your vehicle are legal.

Progressive Rate Coil Springs

We designed our coils to offer more travel and an even better quality ride. The initial and mid range spring rate is soft, which allows them to offer good ride characteristics and travel, without being so soft or firm that predictable handling and ride quality is affected. Some coils are so soft that at maximum extension they don't offer enough pressure down on the axle (and thereby to the tire) to provide traction. This is why some vehicles will do great on RTI ramp but on an actual extreme trail they will have a tendency to hop rather than provide enough down force to the tire for traction. The spring rate increases dramatically the last few inches before full compression, providing bottoming out prevention. **#5106 2 1/2" Lift** **#5107 3 1/2" Lift** **#5109 5 1/2" Lift**

Stage 1 Dual Shock Hoops

Our original hoop shock mounts for 66-77 Broncos offer all the benefits of double shocks and increase front wheel travel to 9 1/2". By removing the travel limiting factory shock tower we have created the ultimate setup for an all-around Bronco. Utilize the same front weld-on lower mount as our #5101 classic double shock mounts. Powder coated in two-tone hammer finish silver vein for corrosion resistance. Bolt on design but we recommend welding to the frame for additional strength. If your Bronco already has our #5101 double shock mounts, they can be bolted through the hoop and used as heavy duty braces.

#5201 Dual Shock Hoops, 66-77 Bronco



Progressive Rate 11 Leaf Spring Packs

These springs are designed to handle the extra weight that many people carry or when a hard top, tire carrier, and rear passengers are carried on a regular basis. With these springs ride and articulation is not hampered in order to handle the extra weight. Feature Teflon wear pads (for quiet operation and less friction), tapered ends and double wrap main eye mounting for superior strength. Work great for handling the extra weight of heavy bumpers combined with all the necessary tools and spare parts that go along with trail use. Unlike many on the market, ours are American Made.

#5560-80 11 Leaf Springs: 2.5-5.5" Lifts

Lower Coil Retainers

Bent up or rusty stock lower retainers? Or your new softer coil springs "bow" after installation? If the problem is excessive on your rig, you can replace the lowers with our retainers which will significantly reduce, if not eliminate the problem. Or just use these as stock replacements, as they are more affordable than reproduction pieces. **#5120 \$75/pr.**



4/4 3/17