

INSTALLATION INSTRUCTIONS:

1966-75 Bronco 2.25" to 2.5" Aluminized 2-1 Exhaust Kit

PART# 3060, 3061 Flow, Pro, Magna, Full Boar



865.938.6696 www.dufftuff.com
6609 Bronco Ln.
Knoxville, TN 37921

CONTENTS:

1 Driver side head pipe (A)	4 2 1/2" Exhaust clamps (J)
1 Pass side head pipe (B)	2 2 1/4-1/2" Stainless Band Clamp (K)
1 Y pipe (C)	1 5/16" x 1 1/4" NC Bolt
1 Mid pipe (D)	4 5/16" Fender Washers
1 Tail pipe (E)	1 5/16" NC Nut
1 Muffler	1 5/16" Lock Washers
1 Long Rubber Hanger (F)	2 1/4" x 1 1/4" Self-drilling Screws
1 Short L bracket (G)	2 5/16" x 1 1/4" Self tapping Hex Bolts
1 Long L bracket (H)	1 Rubber male grommets
2 2 1/4" Exhaust clamps (I)	2 Donut gaskets (L) only for #3061

1/4 10/18

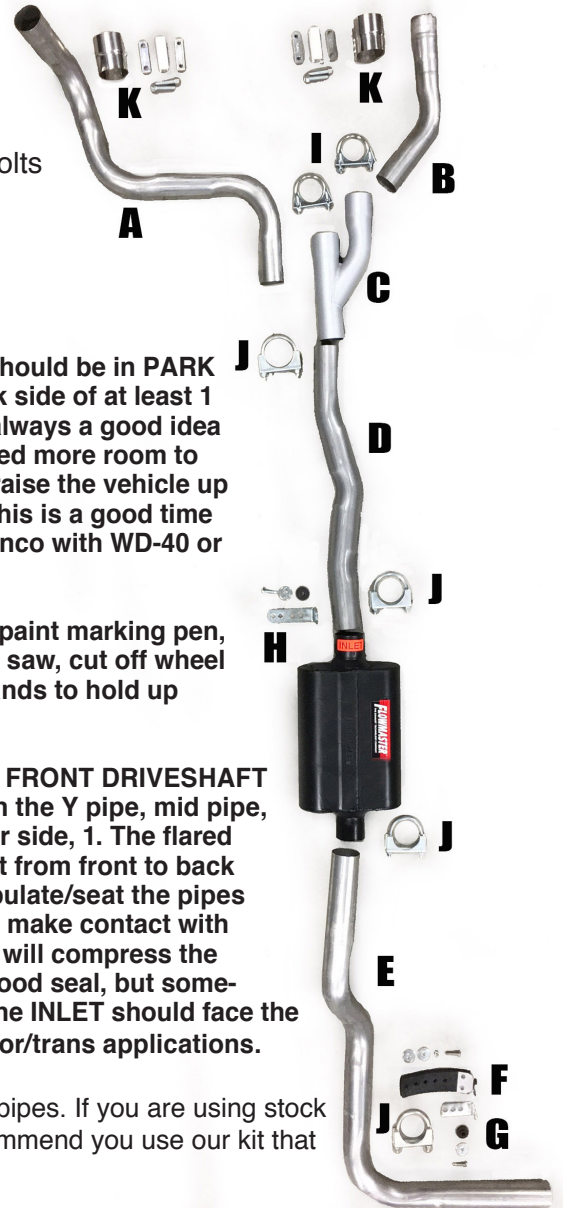

Please read instructions all the way through before beginning.

SAFETY FIRST! Make sure your vehicle is secure before starting. Automatics should be in PARK and manuals should be in 1st GEAR. Also be sure to chock both front and back side of at least 1 tire. Secure the E-brake and disconnect the negative side of your battery. It is always a good idea to wear a pair of safety glasses. Protect your head and hands as well. If you need more room to work underneath your Bronco, you can use 4 jack stands and a floor jack and raise the vehicle up higher. Place jack stands under each axle as far outboard as safely possible. This is a good time to spray any bolts and nuts that attach your original exhaust system to the Bronco with WD-40 or some other rust penetrant and let them soak.

GATHER TOOLS NEEDED: Cordless impact drill, tape measure, silver or white paint marking pen, tape, 5/16", 3/8", 1/2", 9/16", 5/8", 11/16", 17mm, 19mm wrench and socket, hack saw, cut off wheel or vertical band saw, rubber mallet, vice with pipe or soft jaws and two jack stands to hold up muffler & tailpipe during mock up.

NOTES: IN ORDER TO INSTALL THIS KIT AND KNOW IT FITS PROPERLY, THE FRONT DRIVESHAFT MUST BE INSTALLED. The head pipes connect to the headers/manifolds. Then the Y pipe, mid pipe, muffler then tailpipe. The driver side head pipe has 3 bends in it, the passenger side, 1. The flared end of the head pipes point towards the front of the Bronco. Install the exhaust from front to back and make sure you install the clamps loosely at first to allow yourself to manipulate/seat the pipes and muffler. This will give you the flexibility to position each pipe so they don't make contact with the frame, trans crossmember, or fuel tank. Once the clamps are torqued, they will compress the tubes and make it difficult to slide the tubes in or out. This is necessary for a good seal, but something that you only want to do once. When positioning the muffler, remember the INLET should face the engine. You may need to trim some material off the head pipes for certain motor/trans applications.

1. Remove the old exhaust system. This may include the exhaust manifold down pipes. If you are using stock Early Bronco Exhaust Manifolds with our exhaust kit (non emission type) we recommend you use our kit that is made for stock EB manifolds #3061.

2. If you are not using stock Bronco manifolds skip to step 3. Be sure the old donut gasket is completely removed and the manifold studs are not damaged. (Sometimes the studs are not long enough and will have to be removed and replaced with longer studs or swap to a set of bolts.) For studs we used 7/16" x 14 all thread and cut it to length. It is best to replace the nuts at the same time. Install Head Pipes (A & B). Be sure to install both pipes with new donut gaskets (L) seen in FIG 2. Be sure to snug the nuts down firm so the pipes are in the position they will be in once it's time to tighten them down.

3. If you bought our shorty headers at the same time you purchased our 2-1 exhaust kit you will notice the headers did not come with their own instructions. For the most part they are pretty straight forward. IF YOU HAVE A 351W PLEASE READ STEP 4 BEFORE INSTALLING HEADERS. If you have purchased lava wrap from us this would be the best time to wrap your headers with it using the supplied instructions. The driver side is shorter and can be installed from above or below depending on how your Bronco is accessorized. The passenger side can also be installed from above or below on 289/302 & 5.0 but in most cases if you're running a 351W it will need to be installed from below. If the 351W has a C4 or AOD it will be very tight and require patience and a slow steady hand. Make

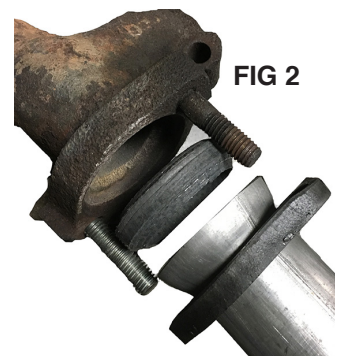

FIG 2

sure to use the supplied header gaskets and start all the bolts by hand starting with the outer ones first. You will not be able to use a socket on all the bolts but we do recommend you use a torque wrench on the ones you can and torque them to 25 foot pounds. Do your best to torque the other bolts down with a wrench the same amount. Once the new exhaust is on and the engine has reached operating temperature you will want to re-torque the header bolts a couple more times until the gaskets are fully seated. Be careful not to burn yourself, those headers get REALLY HOT!

4. If you have a 289/302 or 5.0 based motor, skip to step 5. On 351W based motors, this step is very important. The shorty headers were not specifically designed for the 351W block in an EB, so there are a few mods required to make them fit. You will notice the PS header's two rear primary tubes make contact with the inner fender, some shaping/bending of the fender or the tubes may be required if you don't want them touching. You will also notice the collector flange is very close to the frame. See **FIG 3** for how we recommend to trim away some material from the header collector flange AND the adapter flange so they don't contact the frame when the motor twists. If you ignore this step, your headers will loosen from the head causing exhaust leaks and eventually damage the head.

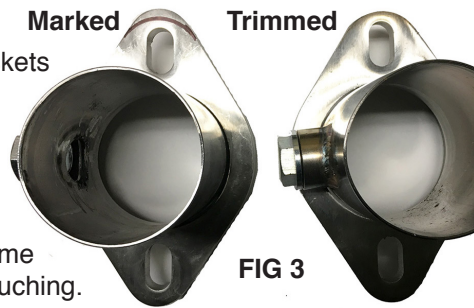

FIG 3

5. If you are installing our head pipes to compatible shorty headers, you will first need to attach the 2 bolt flange adapter (included with headers) to the headers. Be sure to clock the adapter so the O2 sensor bung is facing up and has enough room for the sensor to thread on. It is important that the sensor is not facing down, doesn't have any interference issues and that the wiring coming out isn't kinked or rubbing on anything. Once the adapters are firmly mounted properly, slide Head Pipe **A** inside of it and install Band Clamp **K** around it using the supplied hardware. Do the same with Head Pipe **B**. See **FIG 4**. Be sure not to over tighten any clamps during install. It will take some fiddling and massaging to get all the pipes to slide together. In some applications, pipes **A & B** may need a little trimmed off the front. Trimming may be required for a couple reasons. Sometimes the **A & B** pipes will need to slide deep into the adapter at the header and will not allow the O2 sensor to thread in all the way. Once the head pipe is in position, remove the bolt at the O2 bung & see or feel for clearance issues. Do not cut more than an inch off the front of the **A & B** pipes. If you need to remove more material, do so on the other end. We leave these pipes a little long so they fit many different applications. Bronco's with a 289/302/5.0 with a 2-2.5" suspension lift, may require extra trimming if pipe **A** is too close to the driveshaft. Keep in mind if you have a C4 or AOD do not trim too much or it could make contact with the bottom of your transmission.

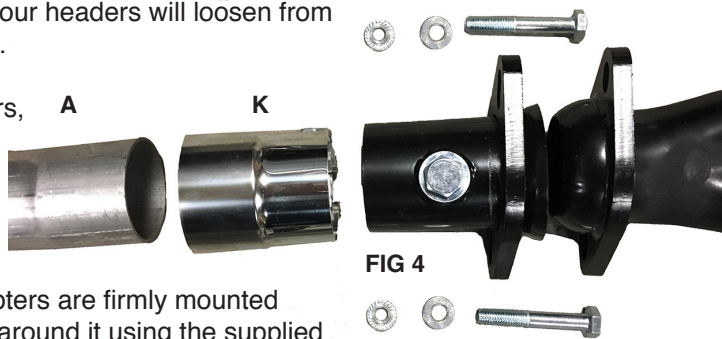

FIG 4

6. To install Y Pipe **C**, first see **FIG 5** then slide the flared ends of Y pipe **C** over Head Pipes **A & B** and loosely install two I's. Tighten them just so they are snug and add a little resistance. Don't overtighten or you will struggle to remove the pipes or move them into their correct position. Position Y-pipe **C** as shown in **FIG 5**. It's very important to do this step so the **A** pipe is in the correct position.

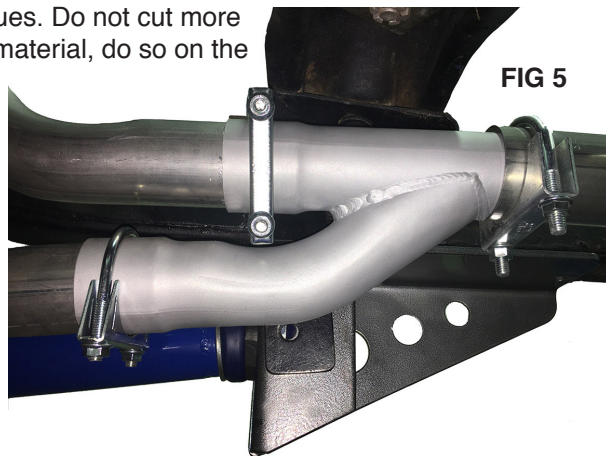

FIG 5

7. Next, install Mid Pipe **D**. Keep in mind it is 2.5" in diameter. Look for an F on the pipe and slide that end over **C**. Use a **J** to clamp it to **C** in the same manner as you did with **C** to **A & B**.

8. This next step will be a lot easier to do using a jack stand. If you don't want your muffler scratched in the process of installing it we suggest using green 3M painters tape and paper to cover it. Before it's installed, this is also the best time to add lava wrap or a heat shield to your muffler to keep excess heat off the floor and out of your Bronco. Both can be purchased at dufftuff.com. Position the muffler so the INLET is facing towards the engine and the FLOW ARROW is pointing towards the rear of the Bronco. With the jack stand close by, slide the muffler over **D**. Let the jack stand hold the muffler up and see **FIGS 6 & 7** on how to install **H & J** to the front of the muffler. You have some freedom to move the exhaust kit into position so it best fits your Bronco, you have a couple inches to move it up or down to where you like it. You can flip **H** up or down or move it to the bottom as well to give you more flexibility. See how the muffler is positioned in **FIG 8** Then tighten **J** to the muffler just enough so the muffler can't twist. Do NOT over tighten it!

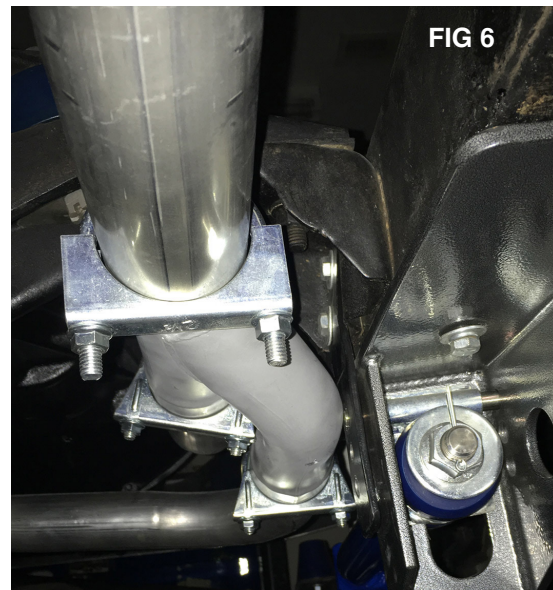

FIG 6

COOL TIP twisting the muffler so it's on an angle like in **FIG 8** helps keep heat off the tub of your Bronco which will keep the interior from getting hot. Don't lean it over too far or the bottom of the muffler will make contact with the frame.

9. **Before** you drill the hole in your frame to mount **H** you will want to test fit the tail pipe and make sure there are no clearance issues. Look for the **F** on the tail pipe and be sure to slide that end into the back of the muffler. From the passenger side rear of the Bronco, snake the tailpipe around the leaf spring and gas tank, over the axle and then slide it into the muffler. Secure it with **J** but do not over tighten it! Using another jack stand, slide it under the tail pipe behind the passenger tire and stand back to see if the pipe is parallel with the ground - See **FIG 10** Once it's parallel you will want to see if it is making contact with the gas tank, bump stop or leaf spring. If you have clearance issues this is where you will have to fiddle with the kit to get everything to fit just right for your Bronco.

10. *STOP & LOOK* IF you have: A aftermarket narrowed high pinion front axle or a rear 4 link you will not be able to use this kit without modifying it. Custom transmission crossmember, inboard rear shock mounts, aftermarket rear bump stops and aftermarket gas tanks all can present challenges to fitting but will not require custom fab. Keep in mind that aftermarket engine mounts, 351W blocks and body lifts (or no body lifts) all change how this kit will fit on your Bronco.

11. Now that you have the exhaust kit complete and it is fitted correctly, it's time to go back and secure it to the frame. See **FIG 9** before starting. That hole below the PS B pillar body mount can be used to secure Long L Bracket **H** to the frame using the supplied 5/16" x 18 self tapping hex bolt. Or if that hole already has a job or doesn't line up to where your exhaust routes and fits the best you can drill a new hole using the supplied self drilling 1/4" screw. The short end of **H** has a large hole in it. Place that part against the frame, place the rubber grommet over the large hole (one side will fit in the hole) and mark or drill through the frame. Sometimes the hole you need to drill will be hard to get to and it will require you to mark the bracket and remove the muffler and mid pipe. In this case, use a paint pen or silver marker and mark the outline of the bracket where it contacts the frame. Then once the exhaust pieces are out of the way you can line the bracket back up with the mark you made and drill the hole. First to last, starting with the frame would be, Frame, bracket, grommet, 5/16" fender washer then 1/4" x 1 1/4" self drilling screw or 5/16" x 1 1/4" self tapping bolt. **SEE FIG 7**

12. Next you will want to secure the tail pipe. Go to the section of the tail pipe that is next to the gas tank directly below the frame. Here you will secure the tail pipe using **J**, **F**, **G** and supplied hardware. **Please SEE FIG 12 on next page.** Keep in mind Short L Bracket **G** mounts in the same fashion as **H** only this time the long portion of the L faces down towards the ground. You most likely will want to trim **F** and **G**. **SEE FIG 10** for how we trimmed ours. We trimmed several inches off ours but every Bronco is a little different so measure twice cut once. Long Rubber Hangar **F** mounts to **G** using the supplied 5/16" x 1 1/4" bolt, 2 - 5/16" fender washers, a 5/16" lock washer and a 5/16" coarse thread nut. Then **F** hooks under **J** and **J** clamps around Tail Pipe **E** and is tightened down to secure **F**. Remember after you have all this assembled, snug it all together firmly but don't tighten it just yet. Remove the jack stands and stand back, take a last look at your tail pipe and make sure it's parallel with the ground and the exhaust pipe isn't making contact with any part of the Bronco. Try to have at least a 1/4" of clearance around every pipe. Some larger gas tanks have a drain on the front bottom PS corner. That drain bolt can sometimes be in the way. If you want to shorten or replace the drain bolt with a shorter one please be careful. Excessive heat and sparks can lead to fire. Always keep a fire extinguisher handy and having another person close by is also very smart.

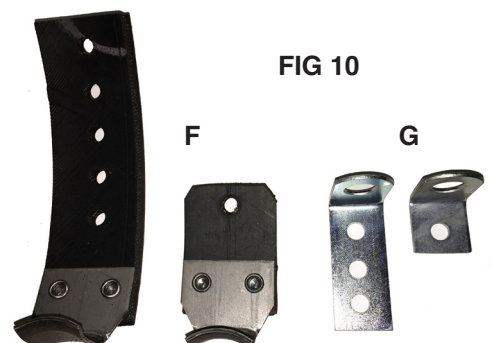
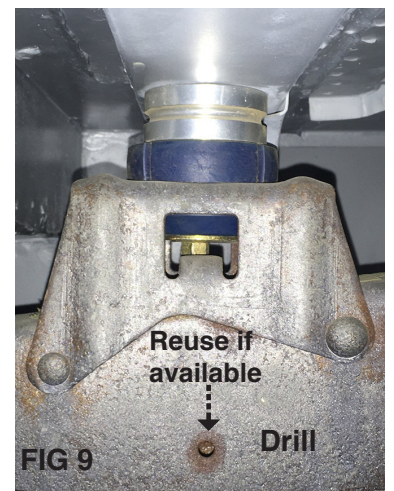
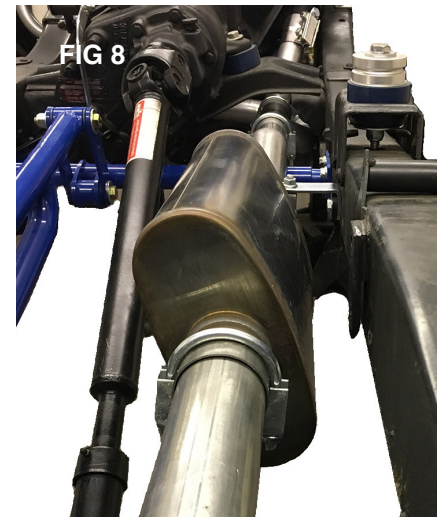
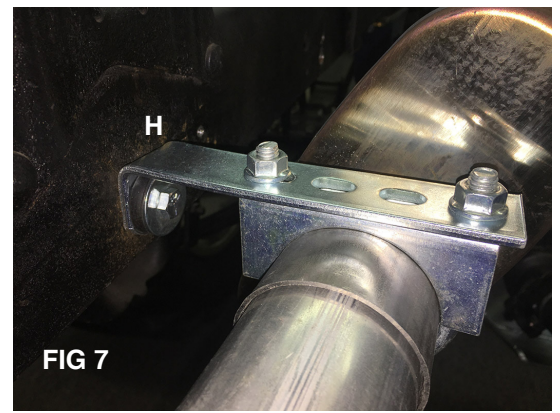

13. Once you have the kit exactly where you like it, go back over it and be sure that the exhaust is not touching anything but itself, the brackets, and exhaust clamps. Feel above the pipes for any contact with wires, e-brake and shifter cables. Make sure the Y & mid pipe are not making contact with the frame and that it is not touching the transmission crossmember. Once you have confirmed all is clear, start from the front and tighten all the bolts, nuts, and clamps. As you're tightening things down, double check the pipes aren't moving and creating contact with anything. Once everything is secured, start the vehicle and check for leaks. They should be immediately apparent by sound and/or by running your hand around each joint and feeling for the exhaust gas. If you discover leaks, turn the vehicle off, and tighten the hardware in that area until the leaks have stopped. Sometimes an air impact gun is required to tighten the clamps down enough to seal out the leaks. Just be careful not to over do it and strip the threads. Now is the time to take a test drive. Listen for any leaks, weird sounds, or vibrations. Make sure to get the exhaust up to operating temperature. Then tighten everything down one last time. Of course, be extra careful when working around the hot components!

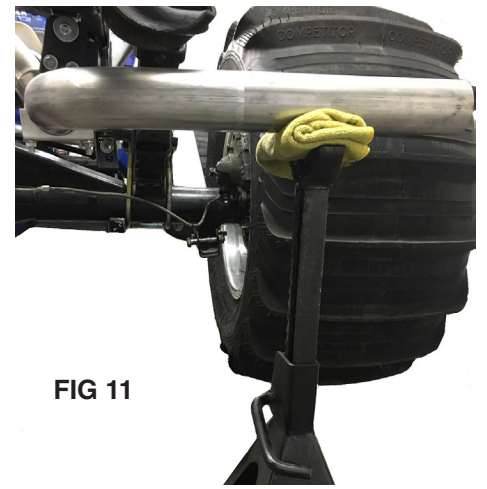

FIG 11

If you decide to go off roading, remember that tailpipe is back there and can easily be damaged if the trail gets rough. Please note that if it is ever damaged beyond straightening, you can purchase just that piece for replacement. We also offer Heat shield products & finished weld on tips if you'd like to dress up your exhaust kit and/or keep the heat out of your Bronco. Visit duffuff.com for all our options. Call us at (865) 938-6696 if you need any assistance or have questions about the install of our parts and accessories. Thank you for choosing Duff products!

NOTE:

ON SOME APPLICATIONS, THE 2-1 EXHAUST KITS CAN MAKE CONTACT WITH THE FRONT DRIVESHAFT IF THE FRONT END BOTTOMS OUT TOO HARD. FOR BRONCOS THAT ARE GOING TO JUMP OR PLAY HARD ON THE SAND DUNES WE RECOMMEND YOU CHECK TO SEE IF YOUR FRONT BUMP-STOPS ARE WORKING PROPERLY AND IF YOU NEED LONGER ONES, GIVE US A CALL OR YOU CAN USE OUR #3095 DUAL EXHAUST KIT INSTEAD.

Other parts referenced:

Lifted Bump Stop Kits #6310 #6312 #6315

Dual Exhaust #3095

Manifold to Dual Exhaust Pipes #3091

Long Tube Headers #3100, #3102

Shorty Headers #3106BK, #3106SS

Shorty to dual exhaust head pipes

Heatshield Products: Lava Wrap, Boot Insulators, Muffler Armor, Heatshield



FIG 12

#3060 & 3061 10/18 4/4

LIMITED WARRANTY

James Duff Inc. warrants our products to the original purchaser to be free from defects in materials and workmanship. Warranty periods begin at the date of purchase and varies by product. Shocks have a limited lifetime warranty. Headers, Radiators and Suspension Products, Power Brake Boosters and Master Cylinders have a one year warranty. Adapters and soft goods such as upholstery, vinyl and rubber products have a 90 day warranty. All warranties are to the original purchaser with proof of purchase only. Such obligations under this warranty shall be limited to the repair or replacement, at JDI's discretion, of any assembly or part which upon examination by JDI proves to be defective. Any costs of removal, installation, reinstallation or freight charges are expressly excluded from this warranty. This warranty covers only manufacturers defects, and does not cover product finish or damage resulting from abuse, misuse, negligence, racing, alteration, accident or damage in transit.

All returns must be pre-authorized by JDI and accompanied with a Return Goods Authorization Number (RGA) and a dated proof of purchase. Returns must be made within 90 days of purchase, shipped prepaid, packaged in sufficiently to prevent damage in shipment and sent to JDI, 6609 Bronco Ln., Knoxville, TN 37921. Returns without an RGA# will be refused.

This warranty is expressly in lieu of all other warranties, expressed or implied, including the implied warranties of merchantability and fitness for use. This warranty gives you specific legal rights including other rights that vary from state to state. Some states do not allow limitations on how long an implied warranty lasts, or do not allow the exclusion of limitation of incidental or consequential damages, so the above limitations and/or exclusions may not apply to you.