

# INSTALLATION INSTRUCTIONS: Early Bronco 3-Speed Floor Shifter

**PART # 2201, 2202**

**CONTENTS: (QTY)**

1. Mounting Bracket (1)
2. Bracket leg (1)
3. 3/8 NF 24X1 Hex Head Cap Screw (2)
4. 3/8 Split Lockwasher (4)
5. 3/8 NF 24 Hex Nuts (6)
6. 3/8 Flatwasher (6)
7. Stiffener Brace (1)
8. 3/8 NC 16X2 Hex Head Cap Screw (1)
9. 7/16 14X3 Hex Head Cap Screw (1)
10. 7/16 Flatwasher (1)
11. 7/16 Split Lockwasher (1)
12. 7/16 14 Hex Nut (1)
13. 3/8 NC 16X3 Hex Head Cap Screw (1)
14. 3/8 Int/Ext Tooth Lockwasher (1)
15. 3/8 NC 16 Hex Nut (1)
16. Rod Adjusting Button (4)
17. Bushing (4)
18. Spring Clip (4)
19. Shift Arm, 1st & Reverse #4746 (1)
20. Rod, 1st & Reverse (1)  
#2202 '68 to early '73 #4742  
or #2201 late '73 to '77 #0062
21. Shift Arm, 2nd & 3rd (1)
22. Rod, 2nd & 3rd #4747 (1)  
#2202 '68 to early '73 #4741  
or #2201 late '73 to '77 #0063
23. Shifter & Handle (1)



865.938.6696 www.jamesduff.com  
6609 Bronco Ln.  
Knoxville, TN 37921

1/3 11/06

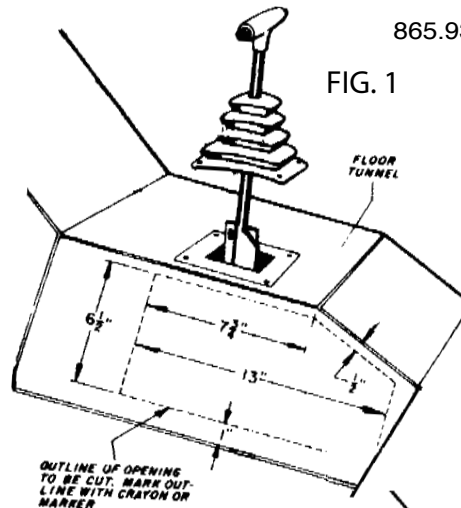

FIG. 1

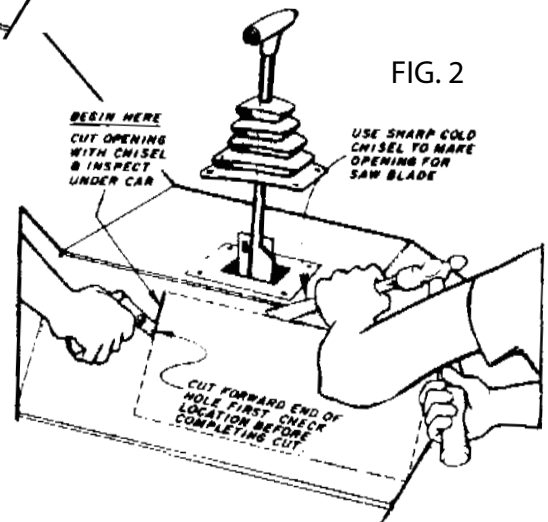

FIG. 2

**ATTENTION:** Due to variations in auto manufacturing tolerances, the transmission rods supplied with this kit may require slight bending to clear obstructions, etc. Protect the threads while bending. **BEND RODS COLD! DO NOT APPLY HEAT!** Please read all instructions before beginning.

1. Lay out the dimensions for the hole to be cut in the transmission tunnel, see Fig. 1. Verify position of cut by placing the tunnel cover over the intended cut lines and insuring they fall under the cover.
2. To cut the hole in the floorboard, start at the cut point indicated in Fig. 2. Check location of cut under floor **BEFORE** completing the cut to assure that the opening is behind the cross-stiffener under the floor pan. Cut the rest of the opening carefully and file the raw edges smooth.
3. Assemble the mounting bracket (1) with the bracket leg (2) using 3/8 bolts, split lockwashers and hex nuts. See Fig. 3. **DO NOT TIGHTEN BOLTS.**
4. Install the mounting bracket/leg assembly onto the adapter flange using the two existing holes. Use stock bolts to fasten the brackets onto the flange, see Fig. 5. **DO NOT TIGHTEN BOLTS.**
5. Remove stock 3/8 bolt from bearing cap at rear of transfer case. Use 3/8 16X2 hex bolt supplied with the kit to attach the stiffener brace in this location as shown in Fig. 4. **DO NOT TIGHTEN BOLT.**

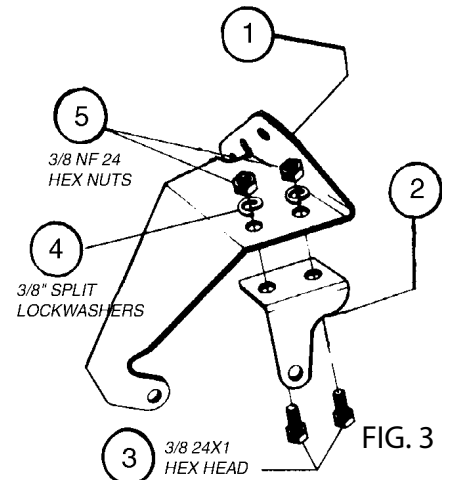

FIG. 3

6. Mount the shifter to the mounting bracket as shown in Fig. 5. Check travel of handle for most desirable position (forward & back) before tightening mounting bolts. Neutral position should be approximately midway between the dash and

the seat, see Fig. 6. TIGHTEN ALL BOLTS.

7. Thread rod adjusting buttons onto rods to about the middle of the threaded length. Assemble shift arms with their respective rods using the bushings & spring clips. The open end of each clip should point towards the nearest end of the rod. Install arm/rod assembly on transmission with the shift arms pointed up, see Fig.5.

8. Locate neutral on the shifter and slide a 1/4" drill bit through the shifter frame and levers, see Fig. 6. After assuring the shift arms are still in neutral, adjust the button on the 2nd & 3rd rod so that the button slides freely into the hole in the shift lever. Fasten the button with the bushing & spring clip. The open end of each clip should point towards the nearest end of the rod.

9. Remove 1/4" drill bit from shifter and shift stick from 2nd to 3rd, see Fig. 7. If shifter is too close to dash or seat, the rod may be removed and the shifter relocated forward or backwards. If so, #8 must be repeated.

10. Repeat steps 8 & 9 in regards to the 1st & Reverse rod. See Fig. 8.

11. The final shifter adjustments are the stop bolts. See in Fig. 8. Place the shifter in 3rd gear and loosen the jam nut on the front stop bolt. Thread the bolt in until it touches the shifter mechanism. Then tighten the jam nut against the shifter frame. Place the shifter in 2nd gear and adjust the rear bolt in the same fashion.

12. With shifter properly adjusted and permanently mounted, next comes the tunnel cover installation. Hold the tunnel cover near the shifter and approximate a location to place a 2" hole for the shifter handle to pass through. Remove the shifter knob and slide the tunnel cover over the shifter. Enlarge the hole as necessary to fit over the shifter mechanism in full travel. When the cover fits flush against the floor, screw it into place with the screws included with the cover.

13. To mount the shifter boot, the front left hand corner will have to be bent to follow the contour of the tunnel cover. After mounting the shifter boot, apply a few drops of medium strength Loctite (not supplied) to the threads of the knob and screw it onto the

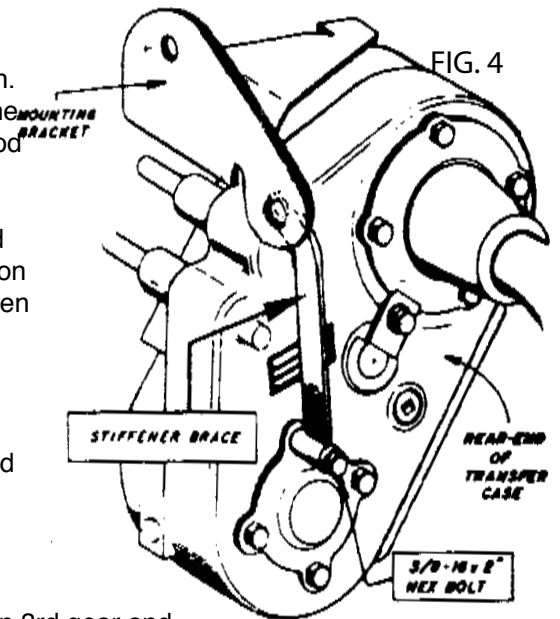
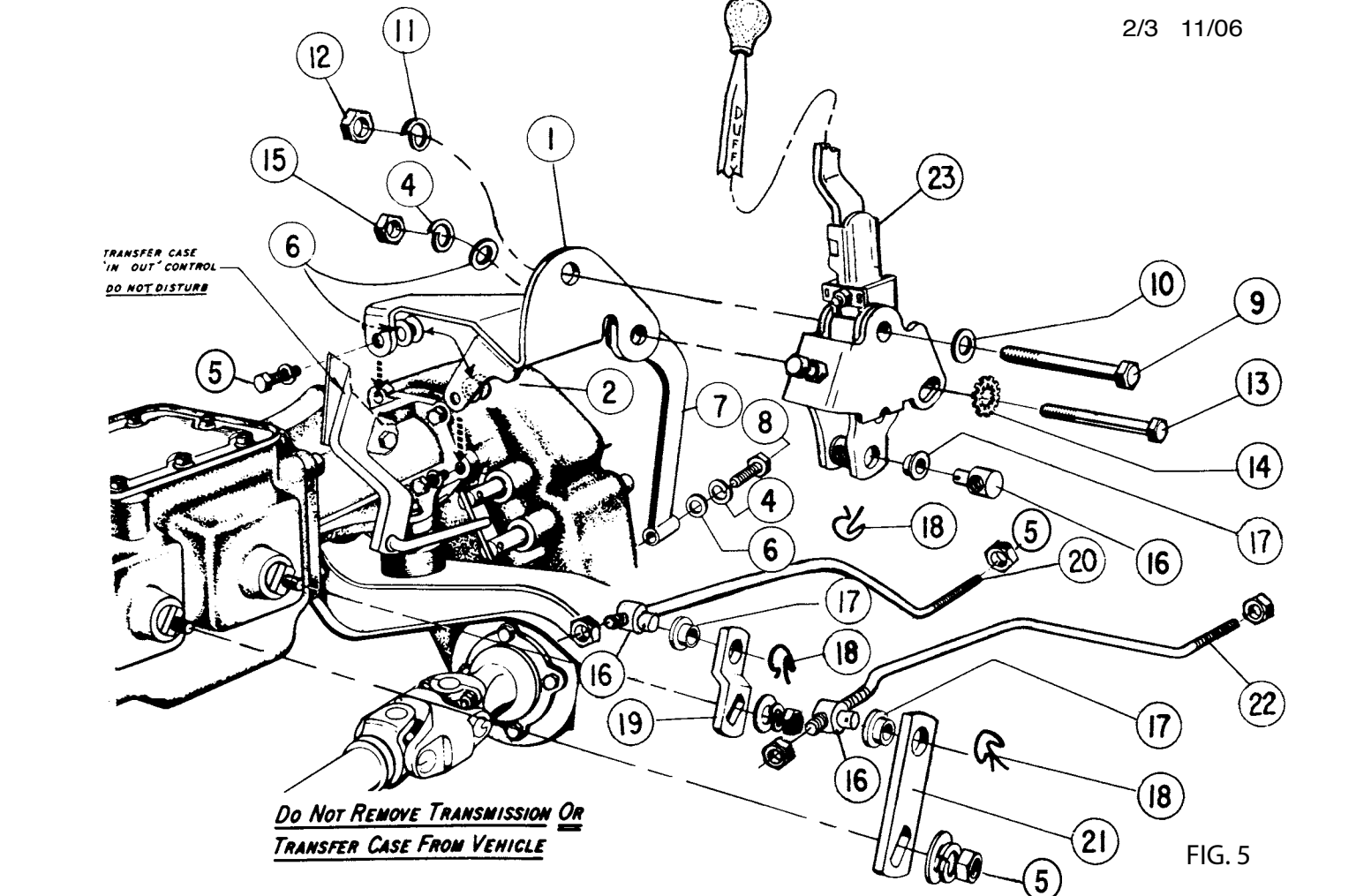
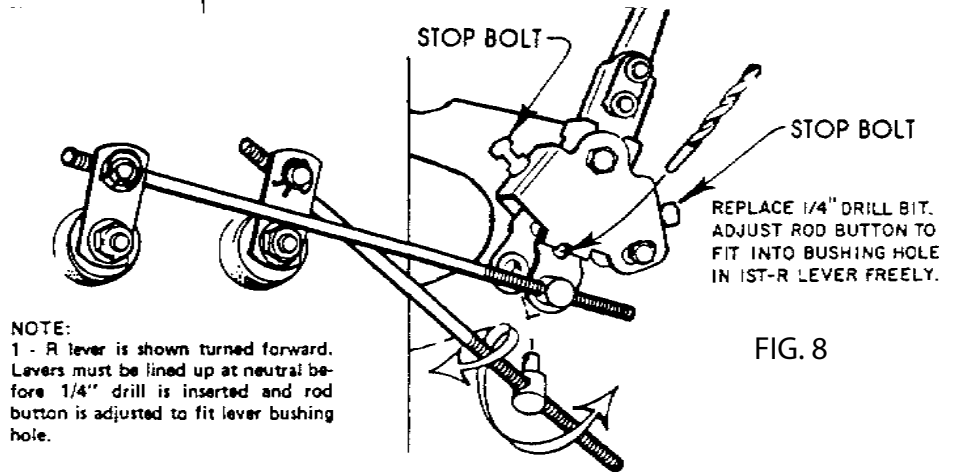
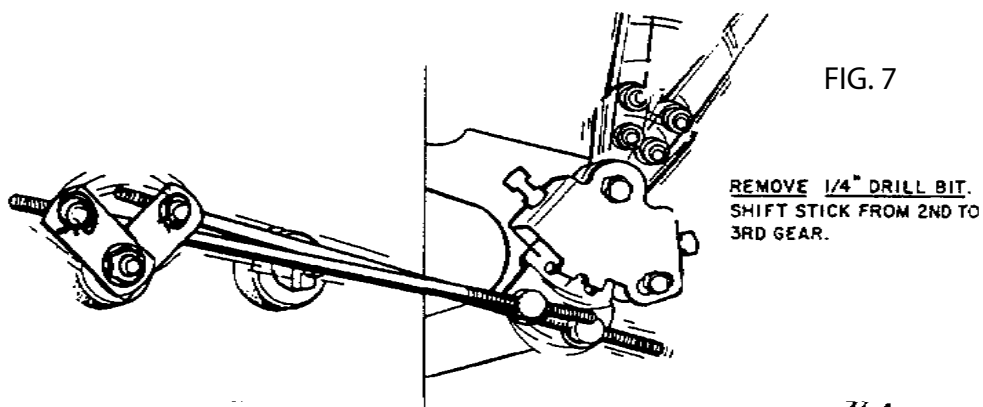
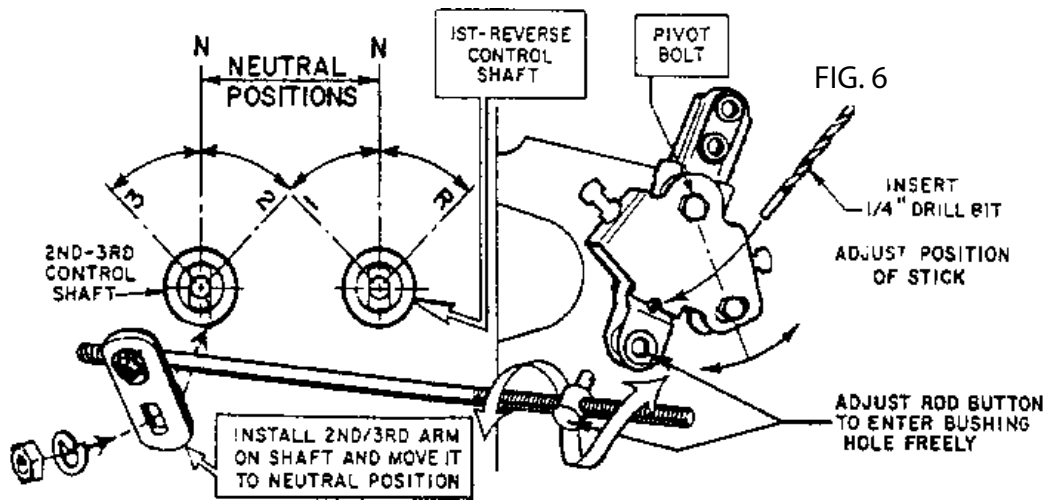

FIG. 4



2/3 11/06

FIG. 5



NOTE:  
 1 - R lever is shown turned forward.  
 Levers must be lined up at neutral before 1/4" drill is inserted and rod button is adjusted to fit lever bushing hole.

#### LIMITED WARRANTY

James Duff Inc. warrants our products to the original purchaser to be free from defects in materials and workmanship. Warranty periods begin at the date of purchase and varies by product. Shocks have a limited lifetime warranty. Headers, Radiators and Suspension Products have a one year warranty. Power Brake Boosters and Master Cylinders have a three year warranty. Adapters and soft goods such as Canvas tops, upholstery, vinyl and rubber products have a 90 day warranty. All warranties are to the original purchaser with proof of purchase only. Such obligations under this warranty shall be limited to the repair or replacement, at JDI's discretion, of any assembly or part which upon examination by JDI proves to be defective. Any costs of removal, installation, reinstallation or freight charges are expressly excluded from this warranty. This warranty covers only manufacturers defects, and does not cover product finish or damage resulting from abuse, misuse, negligence, racing, alteration, accident or damage in transit.

All returns must be pre-authorized by JDEI and accompanied with a Return Goods Authorization Number (RGA) and a dated proof of purchase. Returns must be made within 90 days of purchase, shipped prepaid, packaged in original cartons to prevent damage in shipment and sent to JDI, 6609 Bronco Ln., Knoxville, TN 37921 Returns without an RGA# will be refused.

This warranty is expressly in lieu of all other warranties, expressed or implied, including the implied warranties of merchantability and fitness for use. This warranty gives you specific legal rights including other rights that vary from state to state. Some states do not allow limitations on how long an implied warranty lasts, or do not allow the exclusion of limitation of incidental or consequential damages, so the above limitations and/or exclusions may not apply to you.